

4

3

2

1

ITEM	QTY	PART	DESCRIPTION
1	1	15315	NUT, SHANK, HEX
2	1	15660	WASHER, SHANK, DRAWBAR EYE, 1/2", HEX NUT
3	1	4164	CAPSCREW, 1/4-20 UNC X 1-1/4, HX, GR 5, PLTD
4	1	1374	WASHER, 1/4", SAE, PLTD
5	1	1564	WASHER, 1/4" X 1-1/4", FENDER, PLTD
6	1	1401	NUT, 1/4-20 UNC, METAL LOCK, HX, GR C, PLTD

INSTALLATION INSTRUCTIONS:

1. Remove the old eye and shank assembly. This can be accomplished by removing the shank nut found at the rear of the shock housing. Two large pry bars will need to be used, one to keep the eye from turning and one to back the shank nut off. Heat and or lubrication may be necessary to break the shank nut loose. If the nut is seized such that it can't be removed using a pry bar then removal by a cutting torch may be necessary.
2. Insert the new eye and shank through the shock bushings. A light soapy water solution may be used to lubricate the eye and shank to aid in installation.
3. Place the shank washer over the back of the eye and shank so that it rests against the rear shock bushing.
4. Thoroughly clean the threads of the shank nut and shank. There should be no grease or foreign substances on the threads prior to assembly.
5. Apply a sufficient amount of Loctite 565 Thread Sealant to the threads of the shank that are to be engaged by the shank nut. Follow all manufacturers directions for applying the Loctite product.
6. Thread on shank nut and tighten until the shock bushings bulge around the eye and washer areas in contact with the bushings. This should be on the order of 500 ft-lbs of torque. Since this nut is difficult to tighten with a torque wrench a long pry bar may be used. When using a pry bar the torque can be estimated by multiplying the load applied to the pry bar by the length of the pry bar. For example, if a 3 foot pry bar is used and a 100 pound load is applied to the end of the bar, then a 3*100, or 300 ft-lb torque is achieved.
7. Drill a 9/32" hole through one side of the hex shank nut and shank.
8. Attach the safety wire to the shank and hex shank nut with the capscrew, fender washer, SAE washer and lock nut. See schematic for proper orientation.

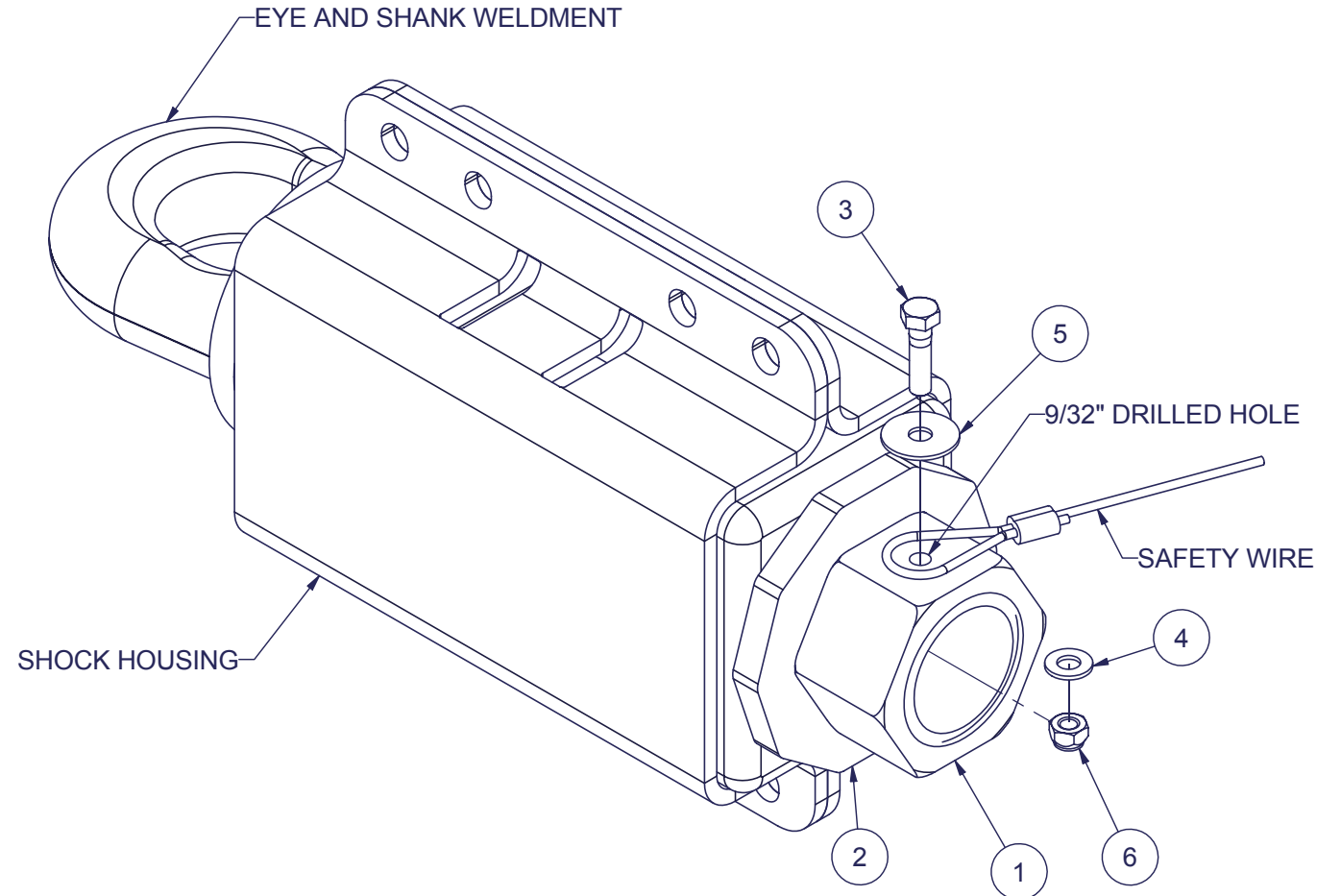

REV	DATE	BY	REVISIONS	ZONE
	DRN			
SILVER EAGLE MANUFACTURING CO., INC.				
5825 N.E. SKYPORT WAY, PORTLAND, OR. 97218				
TITLE				
INSTALLATION INSTRUCTIONS, HEX SHANK NUT				
SIZE		DWG NO		REV
B		15817		
			SHEET	1 OF 1

Silver Eagle Manufacturing Company claims Proprietary rights in the information disclosed hereon. It is agreed that any and all Specifications, Data, and Design Concepts shown shall remain CONFIDENTIAL with the specific understanding that neither this Drawing nor any Reproduction thereof will be disclosed to others or used for the purpose of manufacture or procurement of the article or part shown hereon without written consent of Silver Eagle Manufacturing Company.

TOLERANCES

Fraction 1/16
 1 Decimal .1
 2 Decimal .03
 3 Decimal .010
 Angular 1

DRAWN
gabew

7/7/2003

CHECKED

4

3

2

1